

FICHE TECHNIQUE

CROCHET DE GOUTTIERE HRL 333S

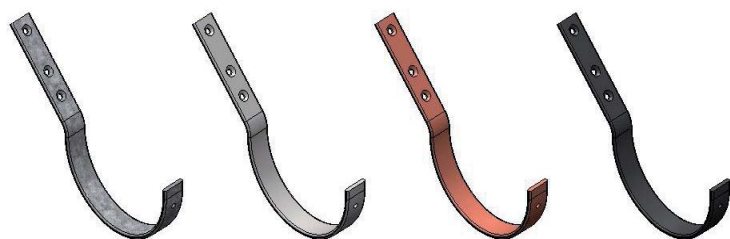

no.Art	matériel	largeur	épaisseur	poids	emballage
HRL333S-G	galva	30 mm	5 mm	455 g	25 p/bte
HRL333S-IN	Inox	30 mm	5 mm	462 g	25 p/bte
HRL333S-K	cuivre	30 mm	5 mm	515 g	25 p/bte
HRL333S-ZW	galva (noir)	30 mm	5 mm	455 g	25 p/bte

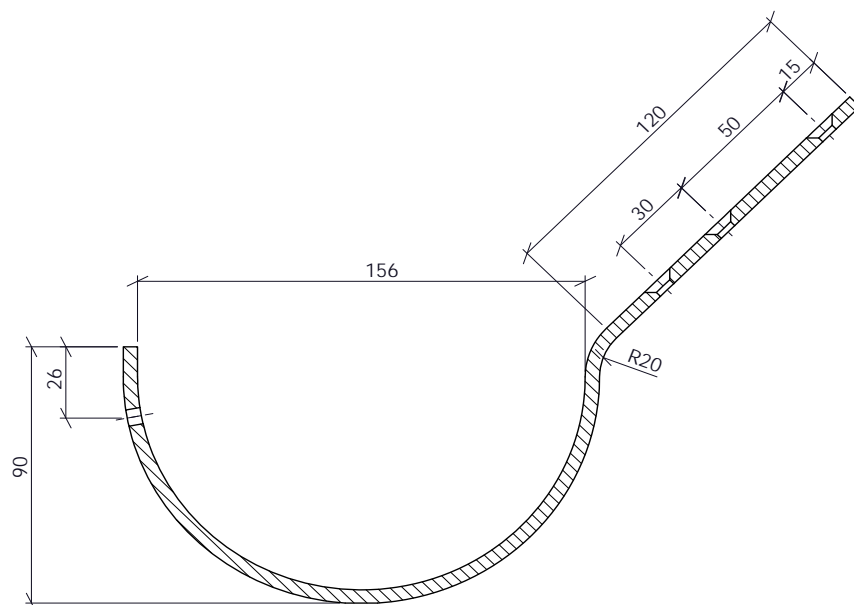

Synonyme de QUALITÉ et SERVICE

APOK KAMPENHOUT
siège principal
Oudestraat 11, B-1910 Kampenhout
Tél.: +32 (0)16 61 72 62 - Fax: +32(0)16 61 72 81
Site: www.apok.be - Email: info@apok.be

